

MS3008 v2

DIMENSIONS [mm]

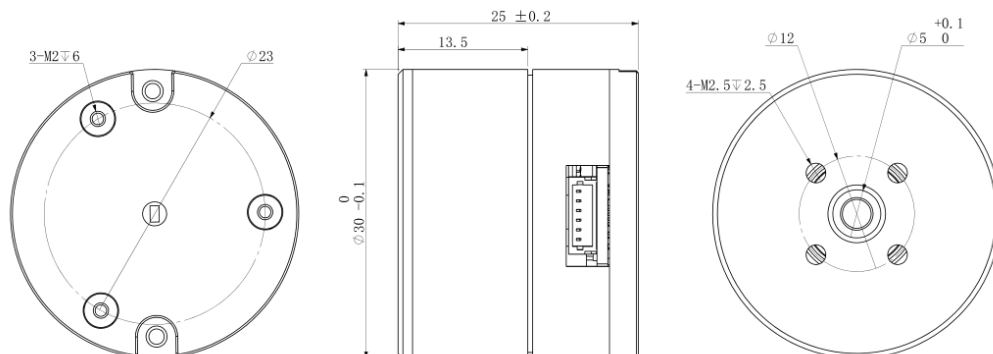

Weight : 49g approx.



MOTOR DATA

Outer Rotor Brushless DC Motor

1	Nominal Voltage	VDC	12
2	Nominal Torque	Nm	0.036
3	Nominal Speed	rpm	1160
4	Nominal Current	A	0.64
5	Max Speed	rpm	2000
6	Max Torque	Nm	0.09
7	Max Current	A	1.65
8	Max Output Power	W	4.6
9	Speed Constant	rpm/V	170
10	Torque Constant	Nm/A	0.06
11	Winding Type		Y
12	Number of Winding Turns		54
13	Resistance (phase to phase)	Ω	6
14	Inductance (phase to phase)	mH	1.68
15	Number of Poles		14
16	Rotor Inertia	gcm ²	35
17	Working Temperature	$^{\circ}$ C	-20~+80
18	Bearing Nominal Load	N	67

DRIVER DATA

32-bit MCU / SVPWM Control / Trapezoidal Acceleration

19	Input Voltage	VDC	6~16
20	Output Current	A	Nominal 1.2 / Max 1.8
21	Encoder		15-bit Absolute Angle-sensing Magnetic Encoder
22	Communication		RS485
23	Communication Frequency	Hz	500 (based on default baud rate)
24	Communication Baud Rate	bps	9.6K, 19.2K, 38.4K, 57.6K, 115.2K(default), 230.4K, 460.8K, 1M, 2M
25	Control Cycle		Open Loop 24KHz / Speed Loop 4KHz / Position Loop 2KHz

DRIVER INTERFACE PIN ASSIGNMENT

Pin --- V+	Power Supply - Positive
Pin --- N2	No Connection 2
Pin --- A	RS485 - A
Pin --- B	RS485 - B
Pin --- N1	No Connection 1
Pin --- V-	Power Supply - Negative
Pin --- T	UART Transmitter
Pin --- R	UART Receiver
Pin --- G	Signal GND

MS3008 v2

CHARACTERISTIC CURVE — Input Current — Efficiency — Output Power — Output Torque

