

## MG10015-i10 v2

### DIMENSIONS [mm]

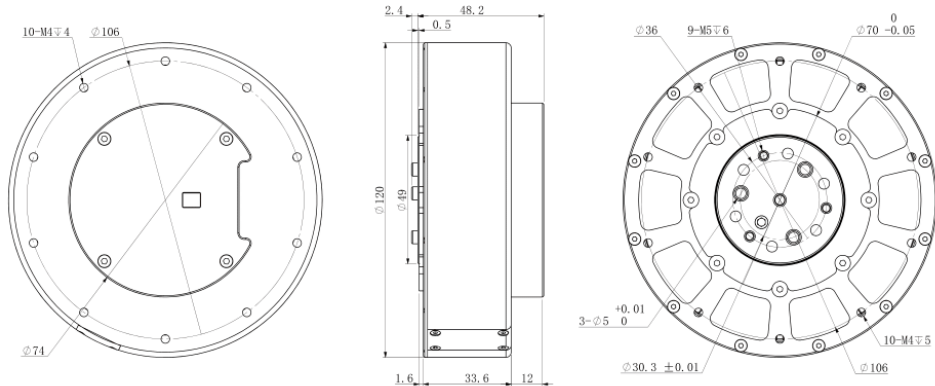

Weight : 1210g approx.



### MOTOR DATA

### Outer Rotor Brushless DC Motor with Planetary Reducer

1	Nominal Voltage	VDC	48
2	Nominal Torque	Nm	25
3	Nominal Speed	rpm	150
4	Nominal Current	A	11.5
5	Max Speed	rpm	185
6	Max Torque	Nm	53
7	Max Current	A	18
8	Max Output Power	W	1200
9	Speed Constant	rpm/V	3.9
10	Torque Constant	Nm/A	2.5
11	Winding Type		$\Delta$
12	Number of Winding Turns		15
13	Resistance (phase to phase)	$\Omega$	0.38
14	Inductance (phase to phase)	mH	0.45
15	Number of Poles		42
16	Rotor Inertia	$\text{gcm}^2$	5668
17	Working Temperature	$^{\circ}\text{C}$	-20~+80
18	Gear Reduction Ratio		10:1
19	Gear Backlash	arcmin	$\leq 8$
20	Bearing Nominal Load	N	1430

### DRIVER DATA

### 32-bit MCU / FOC Control / Trapezoidal Acceleration

21	Input Voltage	VDC	12~60
22	Output Current	A	Nominal 15 / Max 30
23	Encoder for Motor		18-bit Absolute Angle-sensing Magnetic Encoder
24	Encoder for Reducer		None
22	Communication		RS485 or CAN
23	Communication Frequency	Hz	RS485 : 500 / CAN : 2000 (based on default baud rate)
24	RS485 Baud Rate	bps	9.6K, 19.2K, 38.4K, 57.6K, 115.2K(default), 230.4K, 460.8K, 1M, 2M
25	CAN Baud Rate	bps	125K, 250K, 500K, 1M(default)
26	Control Cycle		Torque Loop 32KHz / Speed Loop 8KHz / Position Loop 4KHz

### DRIVER INTERFACE PIN ASSIGNMENT

Pin --- A / H	RS485 - A / CAN - H
Pin --- B / L	RS485 - B / CAN - L
Pin --- V-	Power Supply - Negative
Pin --- V+	Power Supply - Positive
Pin --- A / H	RS485 - A / CAN - H
Pin --- B / L	RS485 - B / CAN - L
Pin --- T	UART Transmitter
Pin --- R	UART Receiver
Pin --- G	Signal GND

## MG10015-i10 v2

### CHARACTERISTIC CURVE

