

MF5010 v2

DIMENSIONS [mm]

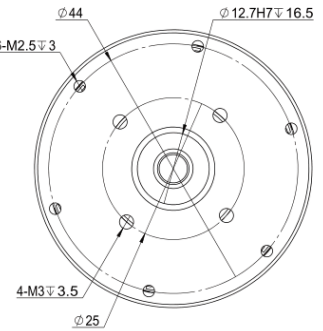

Weight : 135g approx.

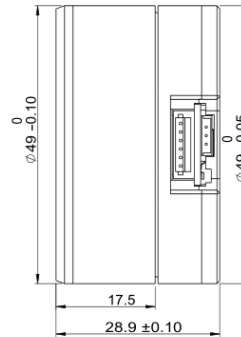
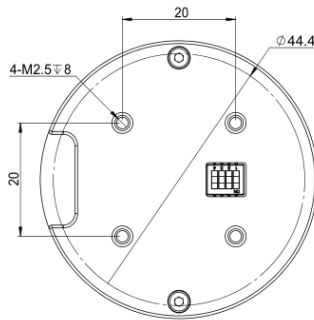

MOTOR DATA

Outer Rotor Brushless DC Motor

1	Nominal Voltage	VDC	16	16
2	Nominal Torque	Nm	0.26	0.24
3	Nominal Speed	rpm	2400	440
4	Nominal Current	A	5.06	1.34
5	Max Speed	rpm	3000	860
6	Max Torque	Nm	2.1	0.53
7	Max Current	A	42.3	3.02
8	Max Output Power	W	128	11.2
9	Speed Constant	rpm/V	190	54.8
10	Torque Constant	Nm/A	0.06	0.19
11	Winding Type		Y	Y
12	Number of Winding Turns		10	35
13	Resistance (phase to phase)	Ω	0.33	3.2
14	Inductance (phase to phase)	mH	0.5	1.2
15	Number of Poles		28	
16	Rotor Inertia	gcm ²	192	
17	Working Temperature	°C	-20~+80	
18	Bearing Nominal Load	N	153	

DRIVER DATA

32-bit MCU / FOC Control / Trapezoidal Acceleration

19	Input Voltage	VDC	7.4~24
20	Output Current	A	Nominal 6 / Max 8
21	Encoder		18-bit Absolute Angle-sensing Magnetic Encoder
22	Communication		RS485 or CAN
23	Communication Frequency	Hz	RS485 : 500 / CAN : 2000 (based on default baud rate)
24	RS485 Baud Rate	bps	9.6K, 19.2K, 38.4K, 57.6K, 115.2K(default), 230.4K, 460.8K, 1M, 2M
25	CAN Baud Rate	bps	125K, 250K, 500K, 1M(default)
26	Control Cycle		Torque Loop 24KHz / Speed Loop 8KHz / Position Loop 8KHz

DRIVER INTERFACE PIN ASSIGNMENT

Pin --- B / L	RS485 - B / CAN - L
Pin --- A / H	RS485 - A / CAN - H
Pin --- V-	Power Supply - Negative
Pin --- V-	Power Supply - Negative
Pin --- V+	Power Supply - Positive
Pin --- V+	Power Supply - Positive
Pin --- T	UART Transmitter
Pin --- R	UART Receiver
Pin --- G	Signal GND

MF5010 v2

CHARACTERISTIC CURVE — Input Current — Efficiency — Output Power — Output Torque

