

## MF4015 v2

### DIMENSIONS [mm]

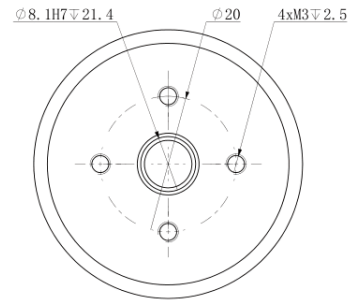

Weight : 120g approx.

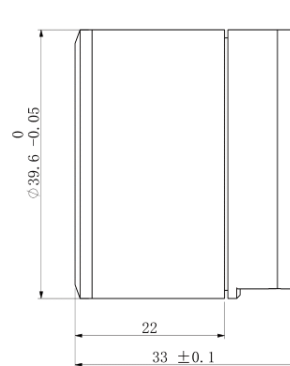
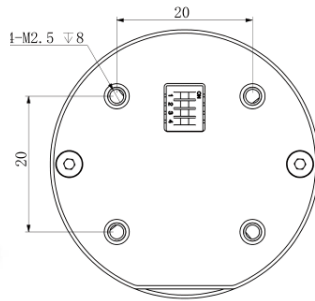

### MOTOR DATA

#### Outer Rotor Brushless DC Motor

1	Nominal Voltage	VDC	16
2	Nominal Torque	Nm	0.25
3	Nominal Speed	rpm	440
4	Nominal Current	A	2.2
5	Max Speed	rpm	1000
6	Max Torque	Nm	0.5
7	Max Current	A	4.3
8	Max Output Power	W	12
9	Speed Constant	rpm/V	63.8
10	Torque Constant	Nm/A	0.12
11	Winding Type		Y
12	Number of Winding Turns		20
13	Resistance (phase to phase)	Ω	2.5
14	Inductance (phase to phase)	mH	0.78
15	Number of Poles		26
16	Rotor Inertia	gcm <sup>2</sup>	105
17	Working Temperature	°C	-20~+80
18	Bearing Nominal Load	N	140

### DRIVER DATA

#### 32-bit MCU / FOC Control / Trapezoidal Acceleration

19	Input Voltage	VDC	7.4~24
20	Output Current	A	Nominal 6 / Max 8
21	Encoder		18-bit Absolute Angle-sensing Magnetic Encoder
22	Communication		RS485 or CAN
23	Communication Frequency	Hz	RS485 : 500 / CAN : 2000 (based on default baud rate)
24	RS485 Baud Rate	bps	9.6K, 19.2K, 38.4K, 57.6K, 115.2K(default), 230.4K, 460.8K, 1M, 2M
25	CAN Baud Rate	bps	125K, 250K, 500K, 1M(default)
26	Control Cycle		Torque Loop 24KHz / Speed Loop 8KHz / Position Loop 8KHz

### DRIVER INTERFACE PIN ASSIGNMENT

Pin --- B / L	RS485 - B / CAN - L
Pin --- A / H	RS485 - A / CAN - H
Pin --- V-	Power Supply - Negative
Pin --- V-	Power Supply - Negative
Pin --- V+	Power Supply - Positive
Pin --- V+	Power Supply - Positive
Pin --- T	UART Transmitter
Pin --- R	UART Receiver
Pin --- G	Signal GND

## MF4015 v2

CHARACTERISTIC CURVE    — Input Current    — Efficiency    — Output Power    — Output Torque

