

机械尺寸

(Dimensions)

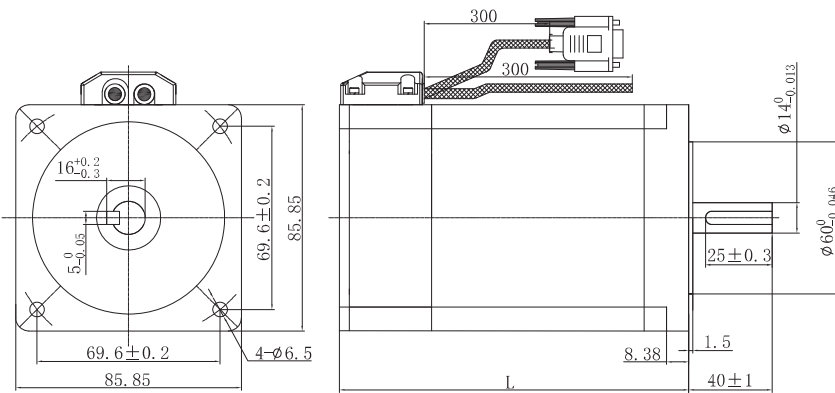

选件 Options



Connector



Gearbox

接插件

齿轮箱

矩频曲线

(Pull out torque curve)

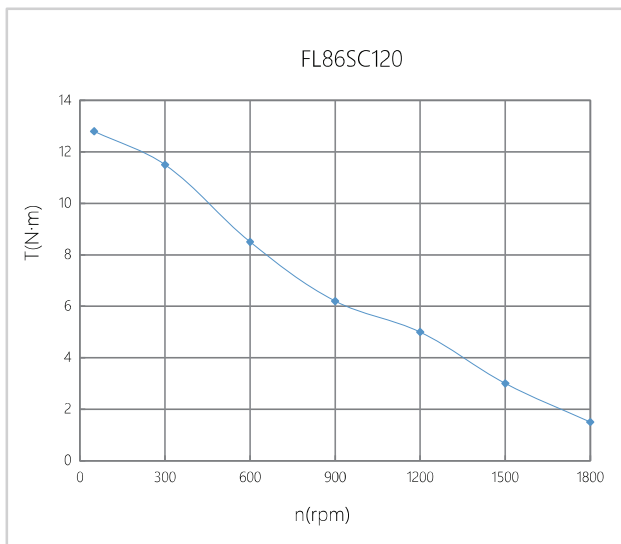
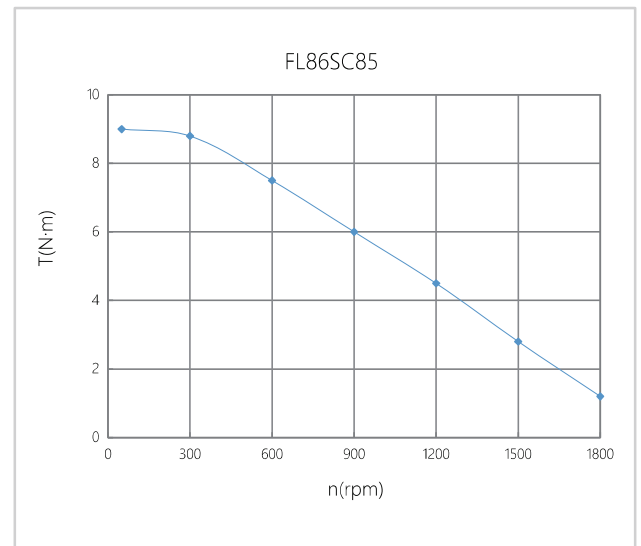
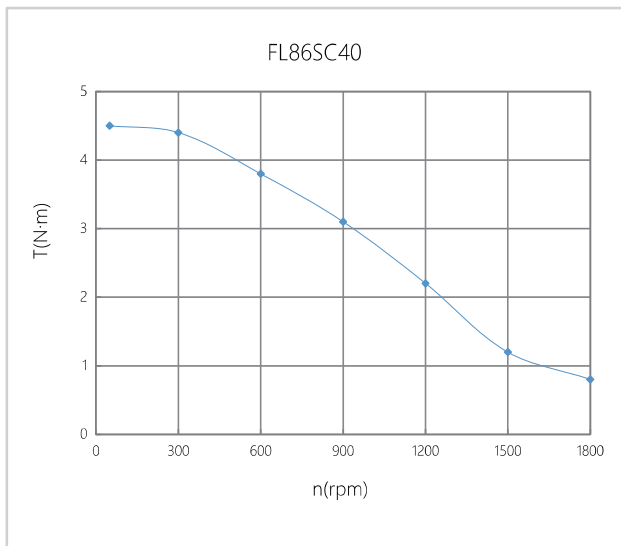

● 一般技术特性 (General Technical Information)

编码器类型 (Encoder type)	1、光电编码器 Optical encoder 2、磁编码器 Magnetic encoder 3、旋转变压器 Resolver 备注: 多种分辨率可选, 增量式、绝对值式可选。 Note: Multiple resolutions are available; Incremental and absolute values are available.		
径向负载 (Max radial force)	130N@20mm from the flange	环境条件 Environmental conditions	使用环境温度: -20°C~ +40°C; Temperature: -20°C~ +40°C 使用环境湿度: ≤90%RH (无凝露); Relative humidity: ≤90%RH(No dewing) 安装环境: 远离腐蚀、可燃性气体, 油滴, 灰尘, 海拔≤1000m(1000~4000m, 降额使用); Installation environment: Far away active gas, Combustible gas, oil drop, ash. altitude≤1000m(1000~4000m, Derating use); 存储环境: -20°C~ +60°C, ≤85%RH (无凝露)。 Storage Condition: -20°C~ +60°C, ≤85%RH(No dewing).
轴向负载 (Max axial force)	36N		
绝缘等级 (Insulation Class)	B		
防护等级 (Protection level)	IP30		

● 电机技术性能 (Motor Technical Specification)

	单位 (Unit)	FL86SC40	FL86SC85	FL86SC120
相电流 (Phase current)	A	6	6	6
保持转矩 (Holding torque)	N·m	4	8.5	12
最高转速 (Speed)	rpm	1800	1800	1800
编码器 (Encoder)		1000cpr光电增量式编码器 1000cpr incremental optical encoder		
转动惯量 (Rotor inertia)	g·cm ²	1400	2700	4000
机身长度 (Motor Length) L	mm	96	133	171
重量 (Weight)	Kg	2.5	3.8	5.5

● 接线说明 (Electric Connection)

序号 No.	引出线颜色 Lead Color	引出线型号 Lead Gauge	功能 Function	说明 Description
3	红白色 (Red/White)	Three rows of 15PIN D-SUB	GND	Signal Power negative
2	红色 (Red)		VCC:+5VDC	Signal Power positive
13	蓝色 (Blue)		EA-	Two-channel differential signal (Three-channel differential signal can be provided).
1	蓝黑色 (Blue/Black)		EA+	
12	黑色 (Black)		EB-	
11	黑白色 (Black/White)		EB+	
1	黄色 (Yellow)	YGZF-S 4*0.75 Cable	A相 (Phase A)	
2	绿色 (Green)		C相 (Phase C)	
3	红色 (Red)		B相 (Phase B)	
4	黑色 (Black)		D相 (Phase D)	