

机械尺寸

(Dimensions)

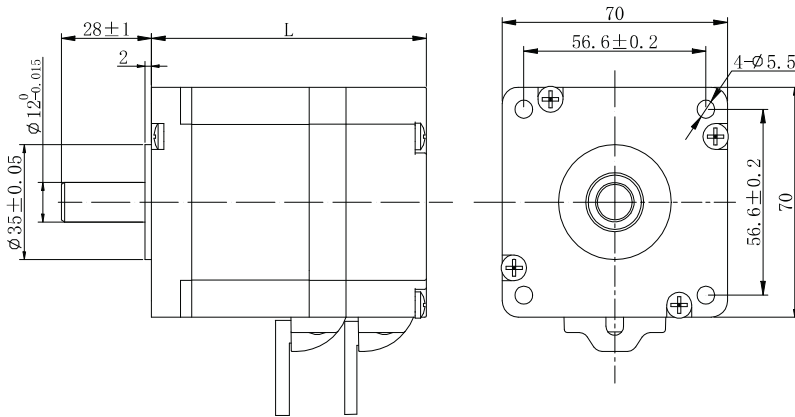

选件 Options



特性概要

(General Specifications)

绕组连接方式 (Winding Type)	星形 (Star connection)
霍尔分布角度 (Hall Effect Angle)	120度电角度 (Electrical Angle of 120 degree)
径向间隙 (Radial Play)	0.02mm@450g
轴向间隙 (Axial Play)	0.08mm@450g
最大径向负载 (Max radial force)	115N 距法兰20mm (20mm From the flange)
最大轴向负载 (Max axial force)	45N
介电强度 (Dielectric Strength)	600VAC/1S
绝缘电阻 (Insulation Resistance)	100MΩ, 500VDC
环境温度 (Ambient Temperature)	-20°C ~ +50°C
绝缘等级 (Insulation Class)	Class B

接线说明

(Electric Connection)

引出线型号 Type	引出线颜色 Color	功能 Functions
UL2464 AWG26	红色 (Red)	霍尔电源正 (Vcc)
	蓝色 (Blue)	霍尔 U (Hu)
	绿色 (Green)	霍尔 V (Hv)
	白色 (White)	霍尔 W (Hw)
	黑色 (Black)	霍尔电源负 (GND)
UL2464 AWG16	黄色 (Yellow)	U相 (Phase U)
	红色 (Red)	V相 (Phase V)
	黑色 (Black)	W相 (Phase W)

电性能

(Electrical Specifications)

	单位 (Unit)	FL70BLS01	FL70BLS02	FL70BLS03
极数 (Number of poles)			8	
相数 (Number of phases)			3	
额定电压 (Rated voltage)	VDC		48	
额定转矩 (Rated torque)	N.m	0.5	1.0	1.5
连续运行转矩 (Continuous stall torque)	N.m	0.6	1.2	1.8
额定速度 (Rated speed)	RPM	3000	3000	3000
额定功率 (Rated power)	W	157	314	471
峰值转矩 (Peak torque)	N.m	1.5	3.0	4.5
峰值电流 (Peak current)	A	13.0	26	38
线电阻 (Line to line resistance)	ohms@20°C	0.6	0.3	0.22
线电感 (Line to line inductance)	mH	1.4	0.7	0.55
转矩常数 (Torque constant)	N.m/A	0.12	0.12	0.12
反电势 (Back EMF)	Vrms/KRPM	9.0	9.0	9.0
转动惯量 (Rotor inertia)	g.cm ²	200	400	600
机身长度 (Motor length) L	mm	86	116	136
重量 (Weight)	Kg	1.3	2.1	2.9