

热敏电阻型号

LTS00-104J395T19E010

REV	ECN	NO	DESCRIPTION	DRN	APP'D	DATE

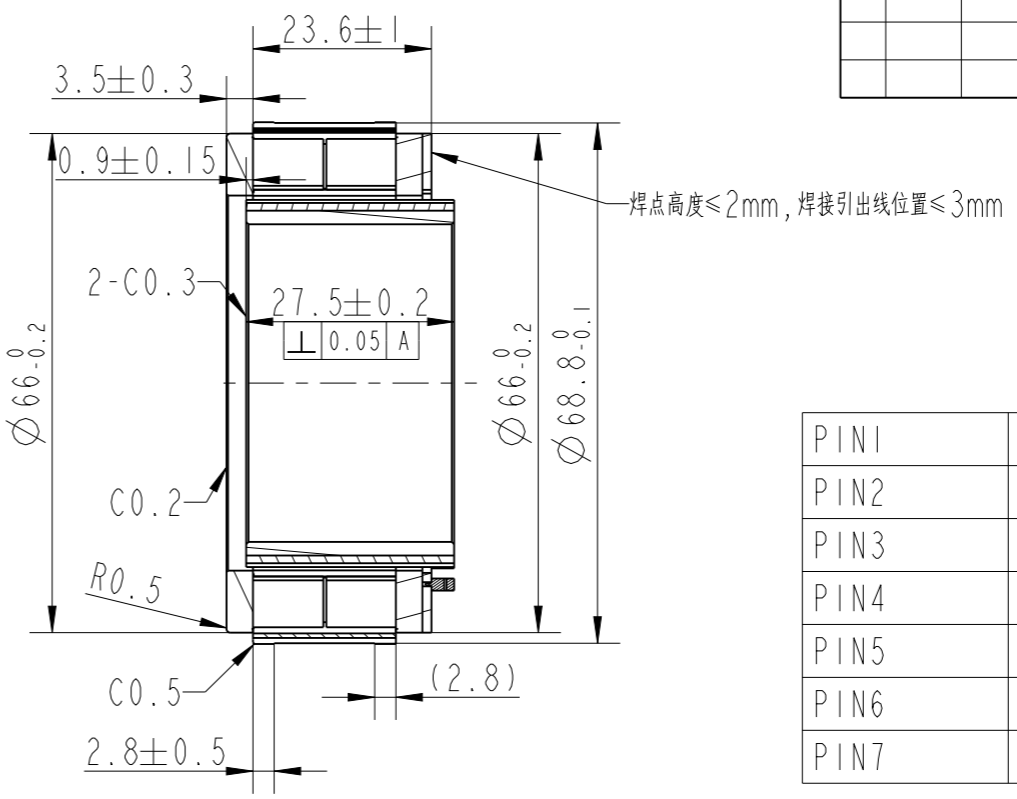
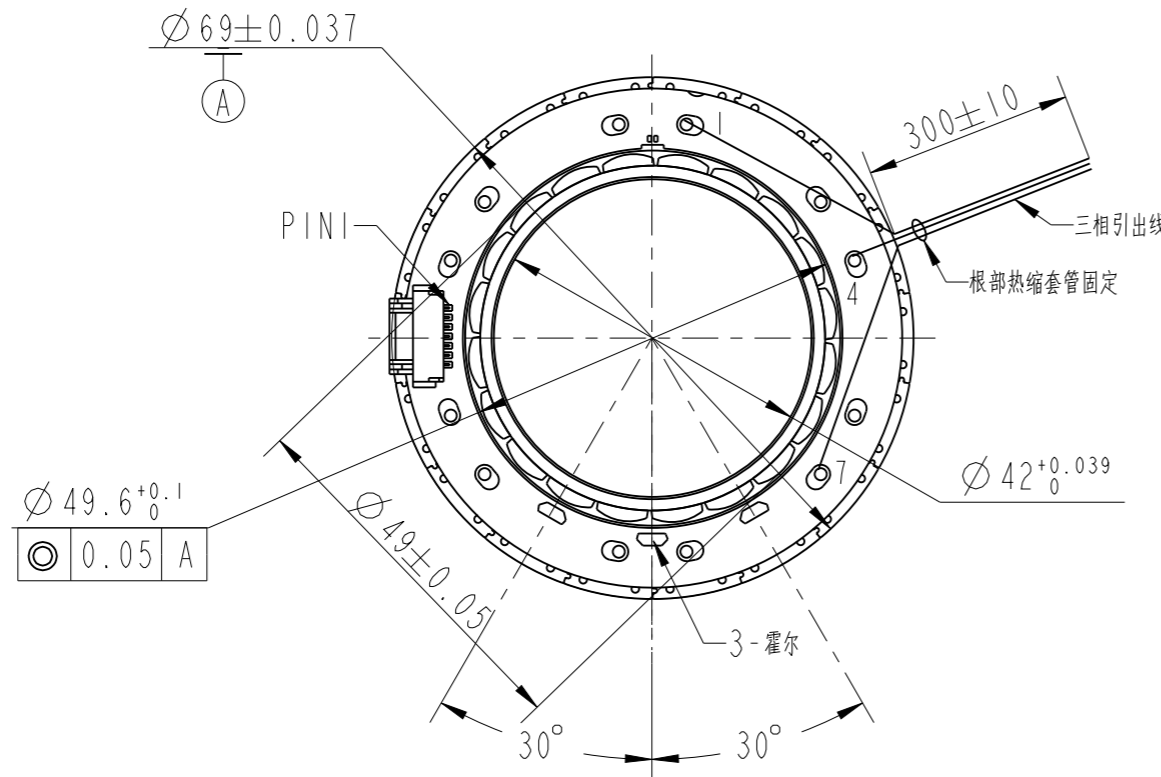

PIN1	NTC2
PIN2	NTC1
PIN3	GND
PIN4	Ha
PIN5	Hb
PIN6	Hc
PIN7	Vcc

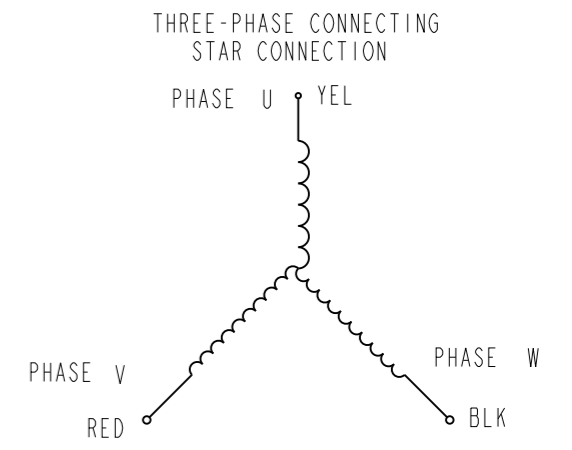
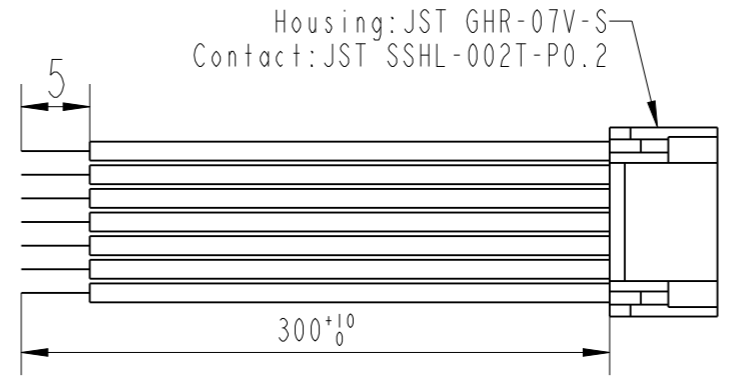
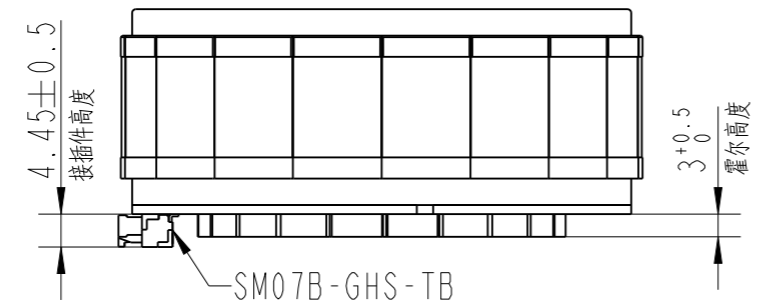

NUMBER OF PHASE	绕组相数	3	Wires for Phases UL1332 AWG18		
NUMBER OF POLES	极数	20	PHASE U	PHASE V	PHASE W
LINE TO LINE RESISTANCE	线电阻	0.19±10% ohms@20°C	YEL	RED	BLK
LINE TO LINE INDUCTANCE	线电感	0.18±20% mH@1kHz	Wires for Hall UL1061 AWG26		
NOMINAL VOLTAGE	额定电压	48 VDC	HALL Vc	Hu	Hv
NO LOAD SPEED	空载转速	4500±10% RPM	RED	BLU	GRN
NO LOAD CURRENT	空载电流	0.6A(REF)	Hw	HWT	BLK
RATED TORQUE	额定转矩	1.0N.m	NTC1	NTC2	
RATED SPEED	额定转速	3500 RPM	YEL	BRN	
RATED CURRENT	额定电流	9.2±5% A	PERMISSIBLE RADIAL+AXIAL FORCE		
PEAK TORQUE	峰值转矩	3N.m			
PEAK CURRENT	峰值电流	28±5% A			
BACK EMF CONSTANT	反电势常数	7.4±10% Vrms/kRPM			
TORQUE CONSTANT	转矩常数	0.12N.m/A			
INSULATION CLASS	绝缘等级	B 130°C	AXIAL-FORCE	轴向压力	/
DIELECTRIC STRENG	介电强度	1000VAC 1SEC	DISTANCE	距离	/
INSULATION RESIST	绝缘电阻	100MOhm @500VDC	RADIAL-FORCE	径向压力	/
ROTOR INERTIA	转子转动惯量	483g.cm <sup>2</sup> (参照图中转子)	SHAFT RADIAL PLAY	径向间隙	/
WEIGHT	重量	320±10%g	SHAFT AXIAL PLAY	轴向间隙	/
OPERATION AMBIENT	使用环境	Ambient temperature: -20...+50°C, humidity Max.85%(No condensation)			
STORAGE AMBIENT	存储环境	Ambient temperature: -20...+85°C, humidity Max.85%(No condensation)			

A		DESIGN	DATE	P/N.
REV	ECN NO.	DESCRIPTION		TITLE
UNLESS OTHERWISE SPECIFIED		MATERIAL	CONTR.	CHECK
TOLERANCES:				
DECIMALS:	ANGULAR:			
.X ±0.5	±0°30'			
.XX ±0.25				
.XXX ±0.1				
UNIT: mm	FIRST ANGLE PROJECTION	SCALE 1:1		
DO NOT SCALE DRAWING		SHEET 1 OF 1		
				电机
				USED ON
				FL70BL19-48V-35366A
				DWG NO.
				REV A
				FULLING MOTOR