

机械尺寸

(Dimensions)

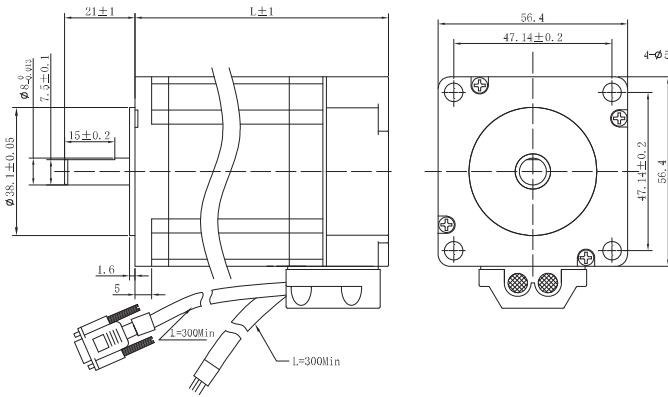

选件 Options



Connector



Gearbox

接插件

齿轮箱

矩频曲线

(Pull out torque curve)

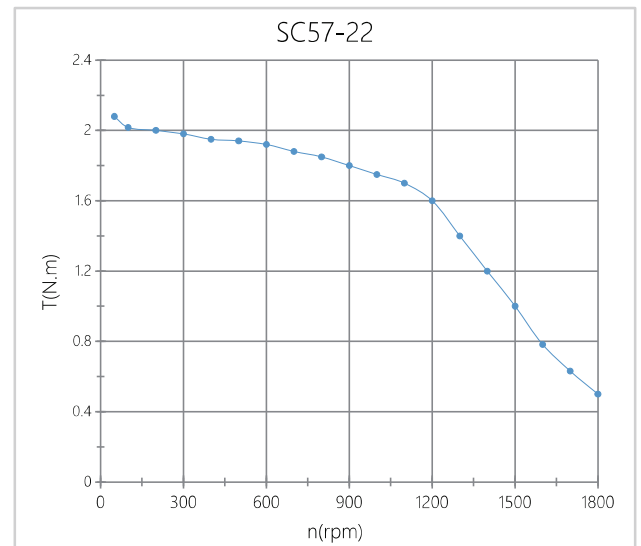
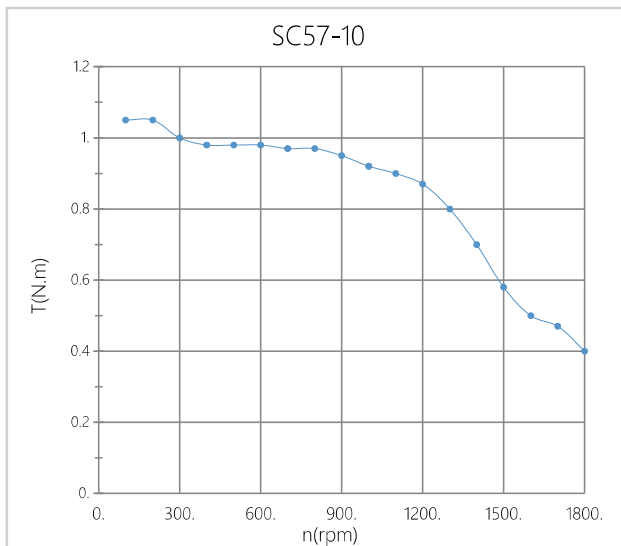

● 一般技术特性 (General Technical Information)

编码器类型 (Encoder type)	1、光电编码器 Optical encoder 2、磁编码器 Magnetic encoder 3、旋转变压器 Resolver 备注：多种分辨率可选，增量式、绝对值式可选。 Note: Multiple resolutions are available; Incremental and absolute values are available.		
径向负载 (Max radial force)	75N@20mm from the flange	环境条件 Environmental conditions	使用环境温度：-20°C~ +40°C; Temperature: -20°C~ +40°C 使用环境湿度：≤90%RH (无凝露) ; Relative humidity: ≤90%RH(No dewing) 安装环境：远离腐蚀、可燃性气体，油滴，灰尘， 海拔≤1000m(1000~4000m，降额使用)； Installation environment: Far away active gas, Combustible gas, oil drop, ash. altitude≤1000m(1000~4000m, Derating use); 存储环境：-20°C~ +60°C, ≤85%RH (无凝露)。 Storage Condition: -20°C~ +60°C, ≤85%RH(No dewing).
轴向负载 (Max axial force)	15N		
绝缘等级 (Insulation Class)	B		
防护等级 (Protection level)	IP30		

● 电机技术性能 (Motor Technical Specification)

	单位 (Unit)	FL575C10	FL575C22
相电流 (Phase current)	A	6.0	5.6
保持转矩 (Holding torque)	N·m	1.2	2.2
最高转速 (Speed)	rpm	1800	1800
编码器 (Encoder)		1000cpr光电增量式编码器 1000cpr incremental optical encoder	
转动惯量 (Rotor inertia)	g·cm ²	300	480
机身长度 (Motor Length) L	mm	74	95
重量 (Weight)	Kg	1	1.5

● 接线说明 (Electric Connection)

序号 No.	引出线颜色 Lead Color	引出线型号 Lead Gauge	功能 Function	说明 Description
3	红白色 (Red/White)	Cable Three rows of 15PIN D-SUB	GND	Signal Power negative
2	红色 (Red)		VCC: +5VDC	Signal Power positive
13	蓝色 (Blue)		EA-	Two-channel differential signal (Three-channel differential signal can be provided).
1	蓝黑色 (Blue/Black)		EA+	
12	黑色 (Black)		EB-	
11	黑白色 (Black/White)		EB+	
1	黑色 (Black)	Cable UL2464 AWG20	A相 (Phase A)	
2	绿色 (Green)		C相 (Phase C)	
3	红色 (Red)		B相 (Phase B)	
4	蓝色 (Blue)		D相 (Phase D)	