

### 机械尺寸 (Dimensions)

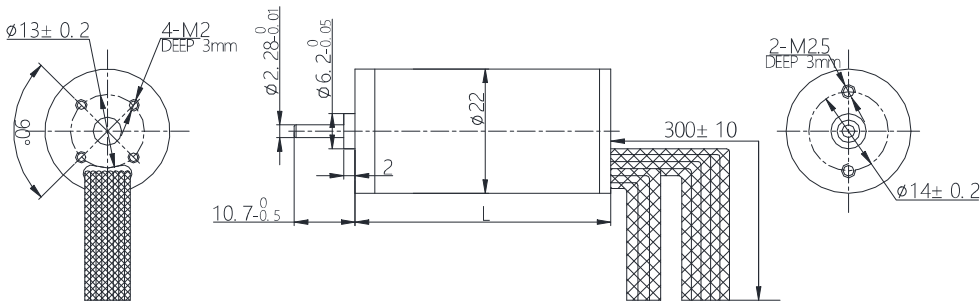

选件 Options



接插件 齿轮箱

### 特性概要 (General Specifications)

|                              |  |
|------------------------------|--|
| 绕组连接方式 (Winding Type)        | 星形 (Star connection)                     |
| 霍尔分布角度 (Hall Effect Angle)   | 120度电角度 (Electrical Angle of 120 degree) |
| 径向间隙 (Radial Play)           | 0.02mm@450g                              |
| 轴向间隙 (Axial Play)            | 0.08mm@450g                              |
| 最大径向负载 (Max radial force)    | 5N 距法兰10mm (10mm From the flange)        |
| 最大轴向负载 (Max axial force)     | 2N                                       |
| 介电强度 (Dielectric Strength)   | 360VAC/1S                                |
| 绝缘电阻 (Insulation Resistance) | 100MΩ, 500VDC                            |
| 环境温度 (Ambient Temperature)   | -20°C ~ +50°C                            |
| 绝缘等级 (Insulation Class)      | Class B                                  |

### 接线说明 (Electric Connection)

| 引出线型号<br>Type | 引出线颜色<br>Color | 功能<br>Functions |
|---------------|----------------|-----------------|
| UL1007 AWG28  | 蓝色 (Blue)      | 霍尔电源正 (Vcc)     |
|               | 黄色 (Yellow)    | 霍尔 U (Hu)       |
|               | 棕色 (Brown)     | 霍尔 V (Hv)       |
|               | 红色 (Red)       | 霍尔 W (Hw)       |
|               | 绿色 (Green)     | 霍尔电源负 (GND)     |
| UL1007 AWG26  | 红色 (Red)       | U相 (Phase U)    |
|               | 棕色 (Brown)     | V相 (Phase V)    |
|               | 黑色 (Black)     | W相 (Phase W)    |

### 电性能 (Electrical Specifications)

|                                  | 单位 (Unit)         | FL22RBL45-24V-4604A | FL22RBL70-24V-3515A |
|----------------------------------|-------------------|---------------------|---------------------|
| 极数 (Number of poles)             |                   |                     | 8                   |
| 相数 (Number of phases)            |                   |                     | 3                   |
| 额定电压 (Rated voltage)             | VDC               |                     | 24                  |
| 额定转矩 (Rated torque)              | mN.m              | 8                   | 20                  |
| 连续运行转矩 (Continuous stall torque) | mN.m              | 9.6                 | 24                  |
| 额定速度 (Rated speed)               | RPM               | 4600                | 3800                |
| 额定功率 (Rated power)               | W                 | 3.8                 | 8                   |
| 峰值转矩 (Peak torque)               | mN.m              | 24                  | 60                  |
| 峰值电流 (Peak current)              | A                 | 1.1                 | 2.0                 |
| 线电阻 (Line to line resistance)    | ohms@20°C         | 23                  | 11.6                |
| 线电感 (Line to line inductance)    | mH                | 6.2                 | 4.3                 |
| 转矩常数 (Torque constant)           | mN.m/A            | 29.7                | 35.8                |
| 反电势 (Back EMF)                   | Vrms/KRPM         | 2.2                 | 2.65                |
| 转动惯量 (Rotor inertia)             | g.cm <sup>2</sup> | 0.66                | 1.32                |
| 机身长度 (Motor length) L            | mm                | 45                  | 68                  |
| 重量 (Weight)                      | Kg                | 0.07                | 0.12                |