

### 机械尺寸

(Dimensions)

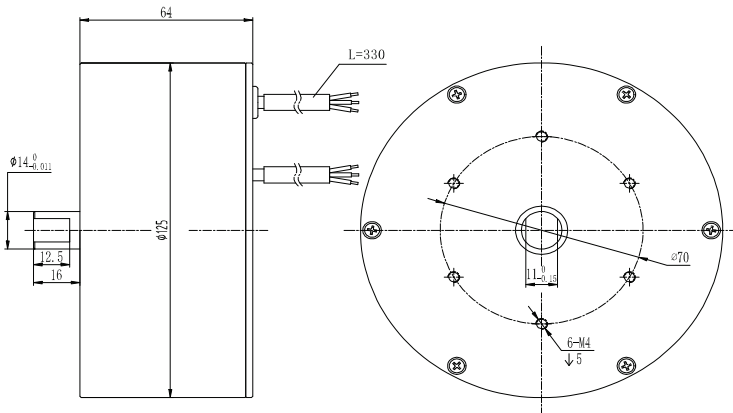

选件 Options



### 特性概要

(General Specifications)

绕组连接方式 (Winding Type)	星形 (Star connection)
霍尔分布角度 (Hall Effect Angle)	120度电角度 (Electrical Angle of 120 degree)
径向间隙 (Radial Play)	0.025mm@460g
轴向间隙 (Axial Play)	0.08mm@4000g
最大径向负载 (Max radial force)	220N 距法兰20mm (20mm From the flange)
最大轴向负载 (Max axial force)	60N
介电强度 (Dielectric Strength)	600VAC/1S
绝缘电阻 (Insulation Resistance)	100MΩ, 500VDC
环境温度 (Ambient Temperature)	-20°C ~ +50°C
绝缘等级 (Insulation Class)	Class B

### 接线说明

(Electric Connection)

引出线型号 Type	引出线颜色 Color	功能 Functions
UL1332 AWG22	红色 (Red)	霍尔电源正 (Vcc)
	蓝色 (Blue)	霍尔 U (Hu)
	绿色 (Green)	霍尔 V (Hv)
	白色 (White)	霍尔 W (Hw)
	黑色 (Black)	霍尔电源负 (GND)
UL3135 AWG14	黄色 (Yellow)	U相 (Phase U)
	红色 (Red)	V相 (Phase V)
	黑色 (Black)	W相 (Phase W)

### 电性能

(Electrical Specifications)

	单位 (Unit)	FL125BL60
极数 (Number of poles)		28
相数 (Number of phases)		3
额定电压 (Rated voltage)	VDC	60
额定转矩 (Rated torque)	N.m	6.8
连续运行转矩 (Continuous stall torque)	N.m	8.16
额定速度 (Rated speed)	RPM	480
额定功率 (Rated power)	W	340
峰值转矩 (Peak torque)	N.m	40
峰值电流 (Peak current)	A	46
线电阻 (Line to line resistance)	ohms@20°C	1.1
线电感 (Line to line inductance)	mH	2.4
转矩常数 (Torque constant)	N.m/A	0.88
反电势 (Back EMF)	Vrms/KRPM	65
转动惯量 (Rotor inertia)	g.cm <sup>2</sup>	2100
机身长度 (Motor length) L	mm	64
重量 (Weight)	Kg	2.9